

PRESA DI FORZA A COMANDO PNEUMATICO

PNEUMATIC CLUTCH POWER TAKE-OFF

CODICE PTO
PTO CODE

52-31

CAMBIO
GEARBOX

EATON



DIAGRAMMA DI UTILIZZO WORKING CONDITION



Tipo cambio Gearbox	Codice PTO PTO code	Versione Version	Giri pto a 1000 giri motore Pto ratio@1000 eng.rpm	Coppia massima Max torque	Lato montaggio Mounting side	Uscita Output	Rotazione Rotation	Kit di montaggio Mounting kit	Peso Weight
Vedi indice See index	52-31-138	13	1022	300	Inf. Bottom	Post. Rear	Ora. Cw	154-3-6023	13,3
	52-31-147	14				Ant. Front	Ant. Acw		
	52-31-2136	213				P/A R/F	O/A C/A		

pag.1

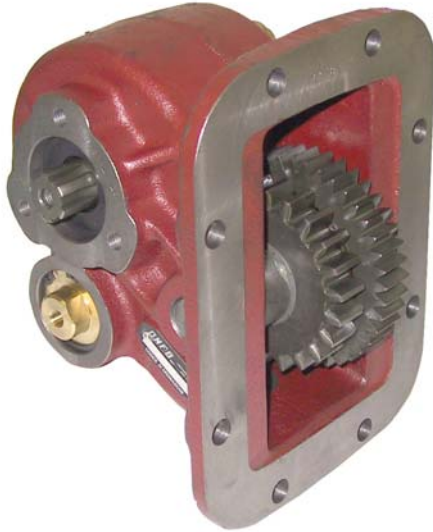
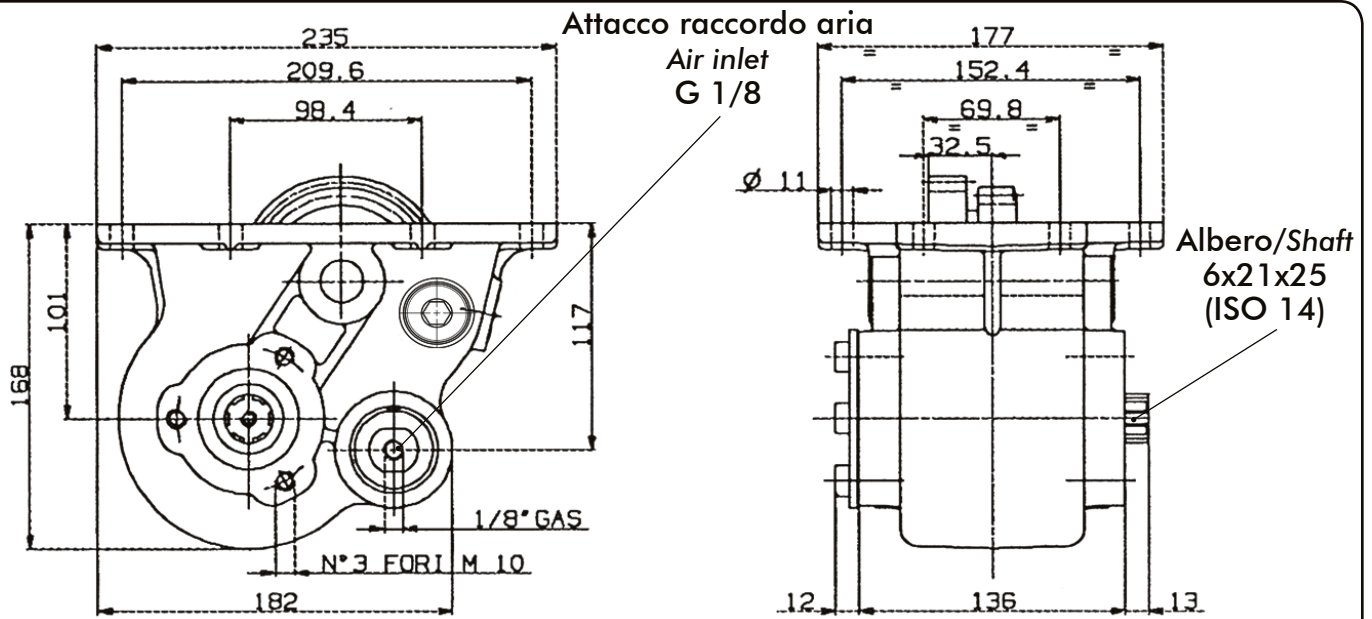
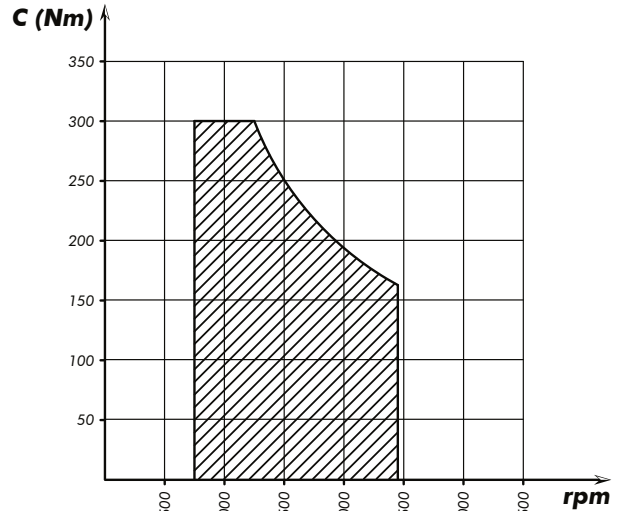

O.M.F.B. S.p.A. Hydraulic Components
We reserve the right to make any changes without notice.
Edition 2004.02 No reproduction, however partial, is permitted.
Via Cave, 7/9 25050 Provaglio d'Iseo (Brescia) Italy Tel.: +39.030.9830611
Fax: +39.030.9839207-208 Internet:www.omfb.it e-mail:info@omfb.it

COMPANY WITH
QUALITY SYSTEM
CERTIFIED BY DNV GL
= ISO 9001 =

Codice foglio: 997-252-03113 Rev: AA

Rev: //

Codice fascicolo:

Data: Giovedì 24 settembre 2009