

PRESA DI FORZA A COMANDO PNEUMATICO

PNEUMATIC CLUTCH POWER TAKE-OFF

CODICE PTO
PTO CODE

50-26

CAMBIO
GEARBOX

FULLER

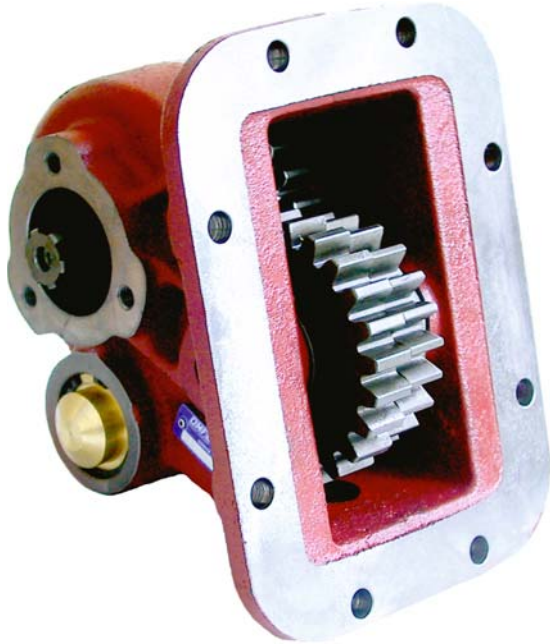

DIAGRAMMA DI UTILIZZO WORKING CONDITION

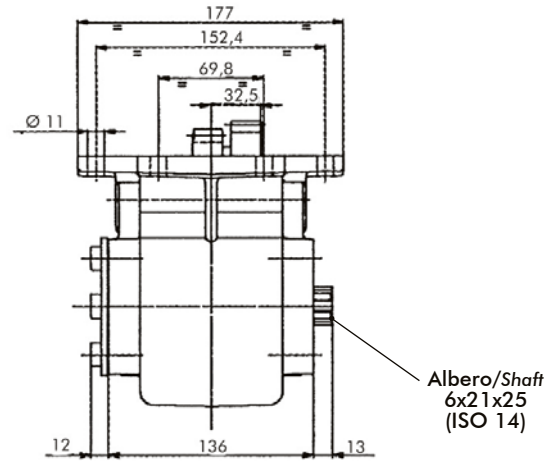
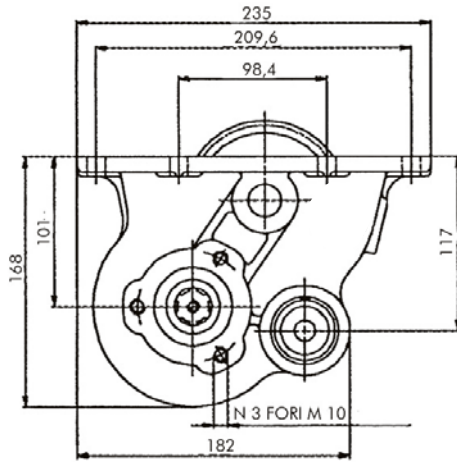
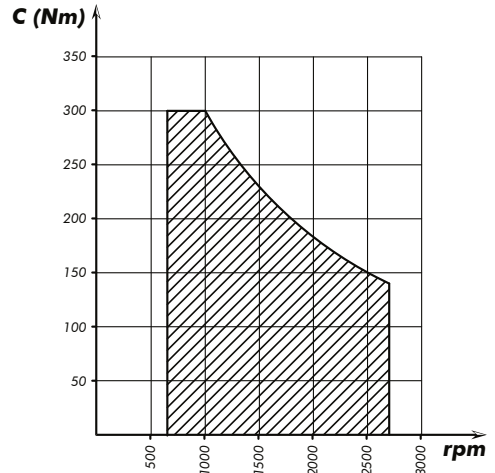

Tipo cambio Gearbox	Codice PTO PTO code	Versione Version	Giri pto a 1000 giri motore Pto ratio@1000 eng.rpm	Coppia massima Max torque	Lato montaggio Mounting side	Uscita Output	Rotazione Rotation	Kit di montaggio Mounting kit	Peso Weight
Vedi indice See index	50-26-139	13	rpm	Nm	Inf. Low side	Post./Ant. Rear/Rew	O/A C/A	154-3-6014	Kg
			Vedi indice See index	300					13,1