

PRESA DI FORZA A COMANDO PNEUMATICO

PNEUMATIC CLUTCH POWER TAKE-OFF

CODICE PTO
PTO CODE

50-25

CAMBIO
GEARBOX

FULLER



DIAGRAMMA DI UTILIZZO WORKING CONDITION

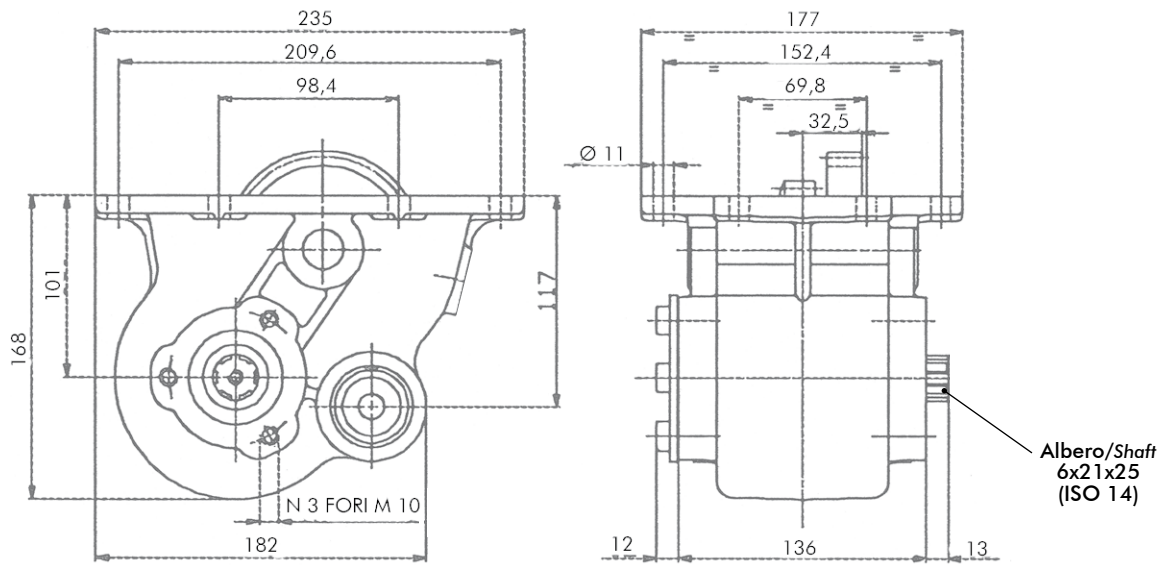
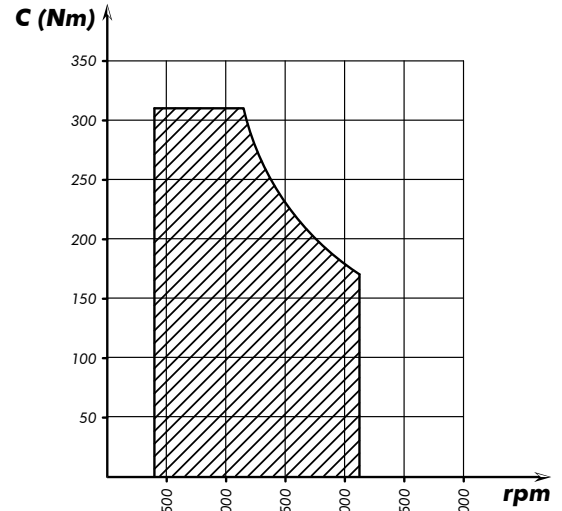

Tipo cambio Gearbox	Codice PTO PTO code	Versione Version	Giri pto a 1000 giri motore Pto ratio@1000 eng.rpm	Coppia massima Max torque	Lato montaggio Mounting side	Uscita Output	Rotazione Rotation	Kit di montaggio Mounting kit	Peso Weight
Vedi indice See index	50-25-130	13	rpm Vedi indice See index	Nm 320	Inf. Low side	Ant. Ccw	Ant. Ccw	154-3-3231	Kg 13,5

pag.1