

PRESA DI FORZA A COMANDO MECCANICO

MECHANICAL CLUTCH POWER TAKE-OFF

CODICE PTO
PTO CODE

1-44

CAMBIO
GEARBOX

IVECO

Codice foglio: 997-201-04469 Rev://



DIAGRAMMA DI UTILIZZO WORKING CONDITION



Rev://

Codice fascicolo:

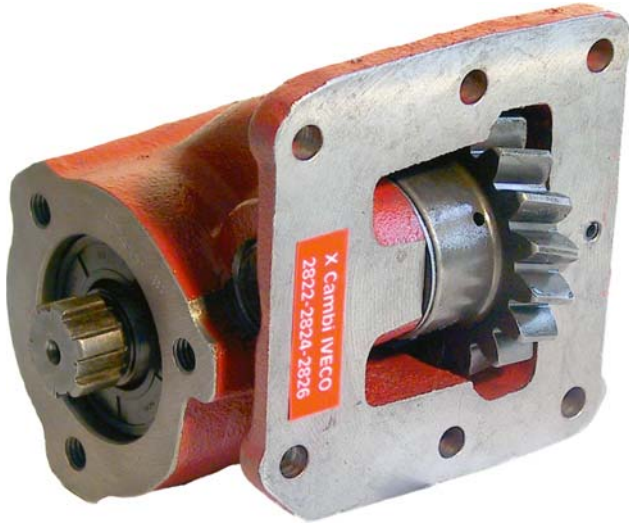
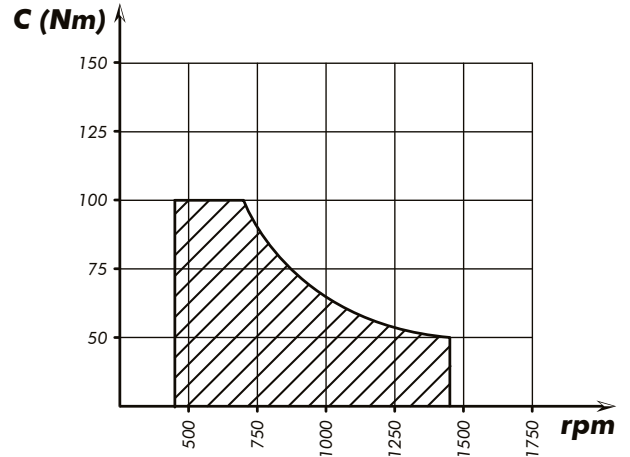
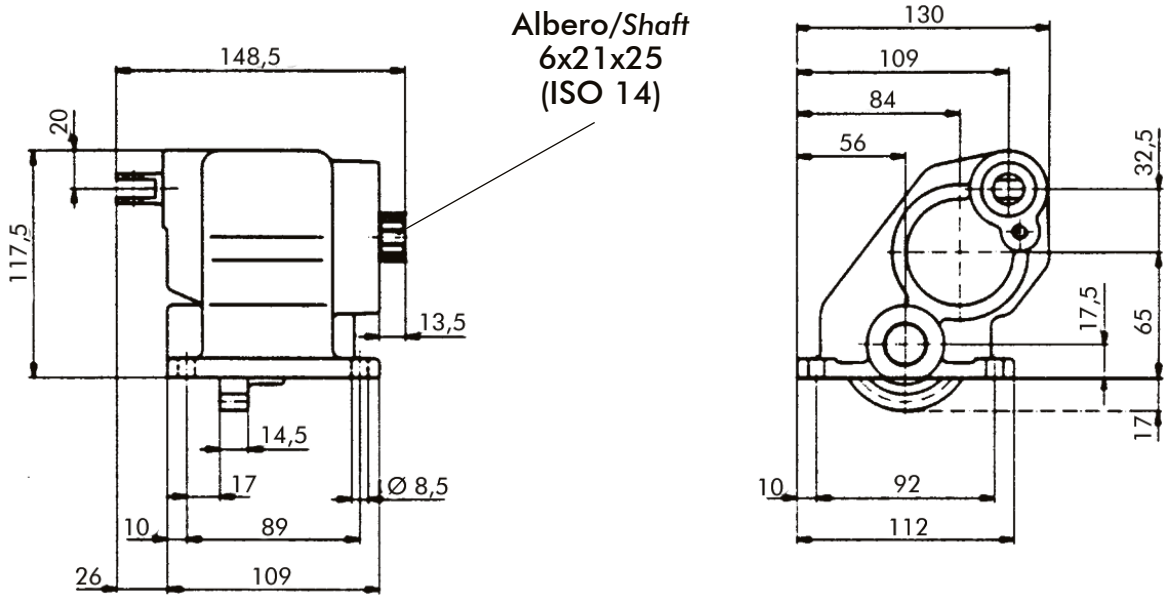

Data: Venerdì 19 dicembre 2003

Tipo cambio Gearbox	Codice PTO PTO code	Versione Version	Giri pto a 1000 giri motore Pto ratio@1000 eng.rpm	Coppia massima Max torque	Lato montaggio Mounting side	Uscita Output	Rotazione Rotation	Kit di montaggio Mounting kit	Peso Weight
			rpm	Nm					Kg
1.128.022.000 1.128.024.000 1.128.026.000	1-44-69	6	465	100	Sx Left	Ant. Ccw	Ora. Cw	154-3-2116	5,5

pag.1



O.M.F.B. S.p.A. Hydraulic Components
We reserve the right to make any changes without notice.
Edition 2003.12 No reproduction, however partial, is permitted.
Via Cave, 7/9 25050 Provaglio d'Iseo (Brescia) Italy Tel.: +39.030.9830611
Fax: +39.030.9839207-208 Internet:www.omfb.it e-mail:info@omfb.it

**COMPANY WITH
QUALITY SYSTEM
CERTIFIED BY DNV GL
= ISO 9001 =**