

For operating condition outside those stated, please consult Casappa S.p.A. Technical sales department

Dimensions w/o tol:
 - Both machining ref.: < 400 ± 0.6; ≥ 400 ± 1
 - One or both rough ref.: ± 3
 Dimensions are in mm.

Signature for approval

 Date: _____

PAGE 1 OF 4

Cap.Forn./Rules Suppl.	Trattamento Termico / Heat Treatment	Trattamento Superficiale / Surface Treatment	Prof.(mm) / Depth
-	-	-	-
Quote senza indicazione di tolleranza / Unless otherwise specified tolerances		Materiale / Material	Durezza / Hardness
GRADO DI PRECISIONE ACCURACY LEVEL		-	-
Disegnato/Drawn	Approvato/Approved	Mod.Tecn./ Release change	Progetto/Project
31-08-2017	31-08-2017	11637	Stato / Process
Firma Signature	RossiC	GuidettiM	File
			02004636
Descrizione / Description			Scala/Scale
POMPA PLP20.4D0-82E2-LEA/EA-N-EL FS			7:10
PUMP PLP20.4D0-82E2-LEA/EA-N-EL FS			Formato/Size
			A3
Codice / Code			Ind. Mod./ Index Rev.
02004636			2
Sostituisce / It replaces			

CASAPPA
 FLUID POWER DESIGN

The information hereon is the property of CASAPPA Spa. Without written permission, any copying, transmittal to others and any use except that for which it's loaned, is prohibited.

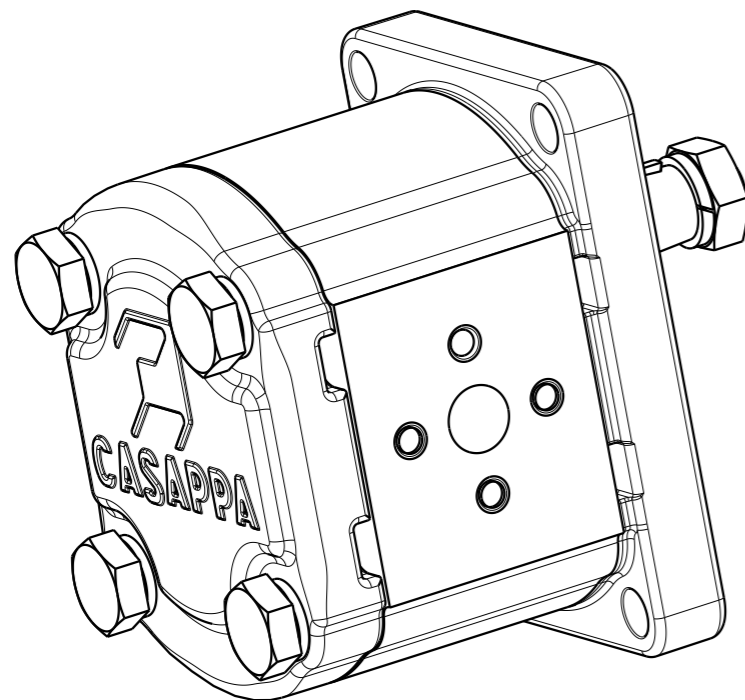
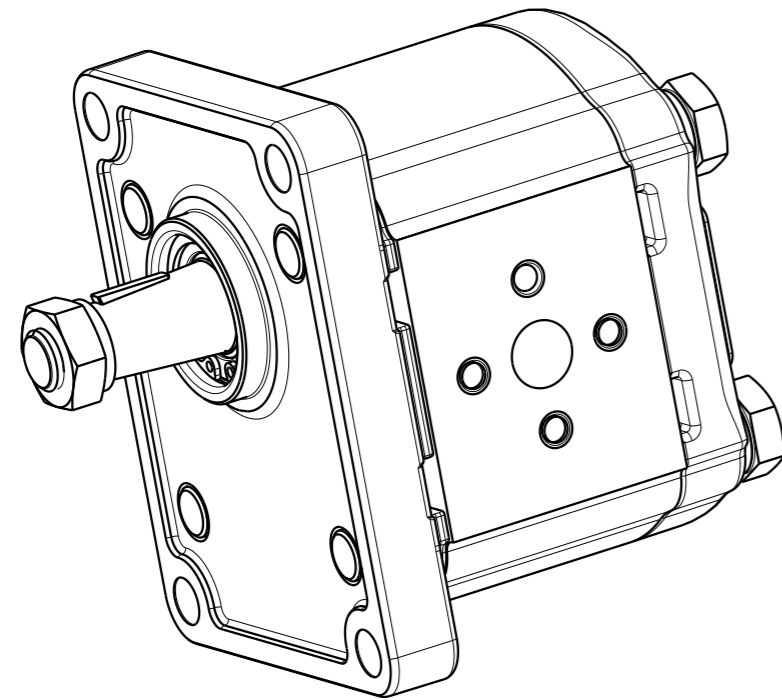

PUMP DATA

Senso di rotazione (guardando l'albero conduttore) Direction of rotation (looking on drive shaft)		Destro (D) Clockwise (D)
Cilindrata - Displacement		4.96 [cm ³ /rev]
Campo pressione di alimentazione per pompe Inlet pressure range for pump		0.7 - 3 [bar abs.]
Pressione max continua - Max continuous pressure	P1	250 [bar]
Pressione max intermittente - Max intermittent pressure	P2	280 [bar]
Pressione max picco - Max peak pressure	P3	300 [bar]
Velocità - Speed	min P1	600 [min ⁻¹]
	max P1	4000 [min ⁻¹]
Guarnizioni - Seals type		NBR
Temperatura di esercizio - Operating temperature		-25 to +80 [°C]
Campo di viscosità - Viscosity range	recommended	12 to 100 mm ² /s (cSt)
	permitted	max 750 mm ² /s (cSt)
Classe di contaminazione - Contamination class	$\Delta p > 200$ bar $\beta x = 75 - 10 \mu m$	8 - Nas 1638
		19/17/14 - ISO 4406
	$\Delta p < 200$ bar $\beta x = 75 - 25 \mu m$	10 - Nas 1638 21/19/16 - ISO 4406
Codice del prototipo - Prototype code		-
Codice cliente - Customer code		-
Valvola di massima pressione - Relief valve		- [bar]
Pressione di stand-by valvola LS - Stand-by pressure LS valve		- [bar]
Peso - Weight		2.280 [kg]
Vernice - Painting		
Trattamenti speciali - Special treatment		

Independently from the max rated pressure values indicated in the table, the max admissible torque of the output shaft and (when applicable) of connecting hub(s) must be respected. Consequently it could be necessary to limit the max working pressures accordingly.

Indipendentemente dai valori di massima pressione riportati in tabella, devono essere rispettate le coppie massime ammissibili su alberi e/o mozzi di trascinamento. Pertanto potrebbe risultare necessario limitare le pressioni massime di esercizio di conseguenza.

Signature for approval

Date: _____

For operating condition outside those stated, please consult Casappa S.p.A. Technical sales department

Cap.Forn./Rules Suppl.	Trattamento Termico / Heat Treatment	Trattamento Superficiale / Surface Treatment	Prof.(mm) / Depth
-	-	-	-
Quote senza indicazione di tolleranza / Unless otherwise specified tolerances		Materiale / Material	Durezza / Hardness
GRADO DI PRECISIONE ACCURACY LEVEL		-	-
Disegnato/Drawn	Approvato/Approved	Mod.Tecn./ Release change	Progetto/Project
Date	31-08-2017	31-08-2017	Stato / Process
Firma Signature	RossiC	GuidettiM	File
			02004636
			Codice Grezzo / Master Code
			-
Descrizione / Description			Ind. Mod./ Index Rev.
POMPA PLP20.4D0-82E2-LEA/EA-N-EL FS PUMP PLP20.4D0-82E2-LEA/EA-N-EL FS			2
Codice / Code	Sostituisce / It replaces		-
02004636			

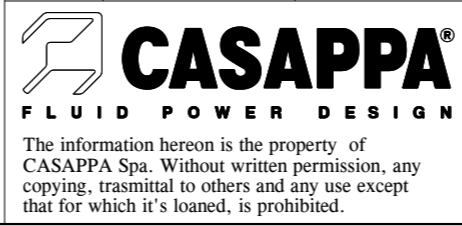

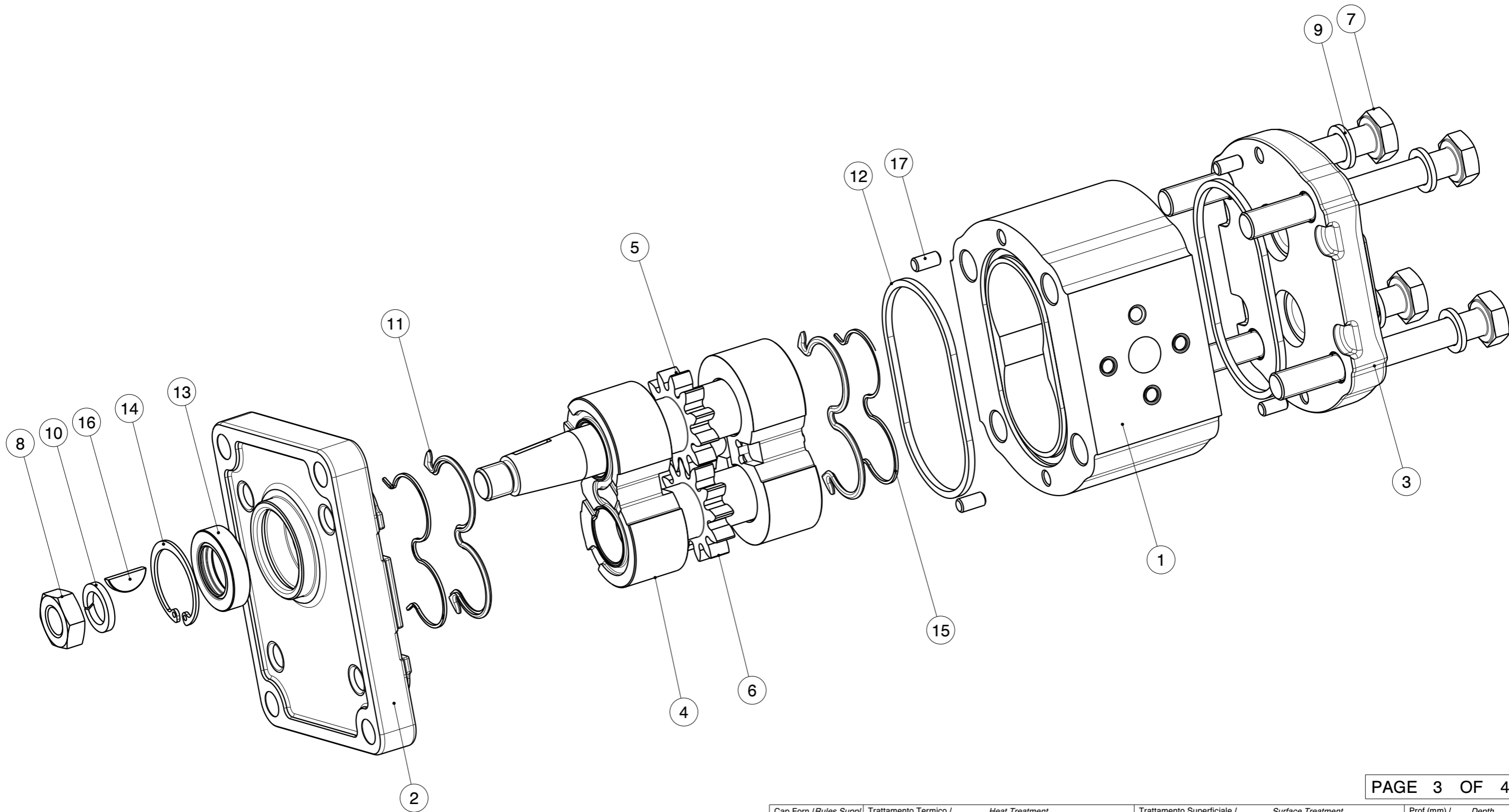

Cap.Forn./Rules Suppl.	Trattamento Termico / Heat Treatment	Trattamento Superficiale / Surface Treatment	Prof.(mm) / Depth
-	-	-	-
Quote senza indicazione di tolleranza / Unless otherwise specified tolerances	GRADO DI PRECISIONE / ACCURACY LEVEL		Durezza / Hardness
-	-		-
Disegnato/Drawn	Approvato/Approved	Mod.Tecn./ Release change	Progetto/Project
31-08-2017	31-08-2017	11637	Stato / Process
Firma / Signature	RossiC	GuidettiM	File
			02004636
			Scala/Scale
The information hereon is the property of CASAPPA Spa. Without written permission, any copying, trasmittal to others and any use except that for which it's loaned, is prohibited.			7:10
Descrizione / Description POMPA PLP20.4D0-82E2-LEA/EA-N-EL FS PUMP PLP20.4D0-82E2-LEA/EA-N-EL FS			Formato/Size A3
Codice / Code 02004636			Ind. Mod./ Index Rev. 2
Sostituisce / It replaces -			

Pos.	Codice Code	Kit	Q.tà Q.ty	Descrizione Description	Indice modifica Index revision
17	49270000		4	SPINA MM.5x10 UNI1707 H8 DOWEL PIN MM.5x10 UNI1707 H8	1
16	42520000		1	LINGUETTA 3.15X6.5 280 HB KEY 3.15X6.5	1
15	41387101		2	ANTIESTRUSORE PL-K20 S/D Z (SIC) (BZ) ANTIEXTRUSION PL-K20 S/D Z (SIC) (BZ)	5
14	40661000		1	ANELLO 30 UNI 7437-DIN 472 RING 30 UNI 7437-DIN 472	0
13	39700000		1	PARAOLIO BABSL 18X30X7 SHAFT SEAL BABSL 18X30X7	1
12	39666195		2	GUARNIZIONE PL 20 STANDARD SEZIONE QUADRATA STANDARD SEAL PL 20 SQUARE SECTION	0
11	39656101		2	GUARNIZIONE PL-K20 S/D (SIC) (BZ) SEAL PL-K20 S/D (SIC) (BZ)	1
10	37583803		1	ROSETTA 12 DIN 7980 GEOMET 321/A WASHER 12 DIN 7980 GEOMET321/A	0
9	37583716		4	ROSETTA 10 (10,5x16x2) HV300 GEOMET 321/A WASHER 10 (10,5x16x2) HV300 GEOMET 321/A	0
8	36860000		1	DADO M 12X1,5 UNI 5589-A-6S-GEOMET 321/A PLUS M NUT M 12X1,5 UNI 5589-A-6S-GEOMET 321/A PLUS M	0
7	36593002		4	VITE TE M 10X85 - 5737 - 10.9 GEOMET 321/A PLUS M SCREW TE M 10X85 - 5737 - 10.9 GEOMET 321/A PLUS M	0
6	27750000		1	INGR.CONDOTTO F-K-PL20.4 DRIVEN GEAR F-K-PL20.4	4
5	27720842		1	INGR.CONDOTTORE PL20.4-82/FS DRIVE SHAFT PL20.4-82/FS	7
4	25930383		2	RASAMENTO PL20 S/D R05 (GGB) THRUST PLATE PL20 S/D R05 (GGB)	2
3	21915751		1	COPERCHIO POST. PL20/AL REAR COVER PL20/AL	4
2	21911152		1	COPERCHIO ANT.PL20/AL FRONT COVER PL20/AL	9
1	17672134		1	CORPO PL20.4-LEA/EA (H = 51,5) BODY PL20.4-LEA/EA (H = 51,5)	10

Cap.Forn./Rules Suppl.	Trattamento Termico / Heat Treatment		Trattamento Superficiale / Surface Treatment		Prof.(mm) / Depth
-	-		-		-
Quote senza indicazione di tolleranza / Unless otherwise specified tolerances			Materiale / Material		Durezza / Hardness
GRADO DI PRECISIONE ACCURACY LEVEL			-		-
Disegnato/Drawn	Approvato/Approved	Mod.Tecn./Release change	Progetto/Project	Stato / Process	Scala/Scale
31-08-2017	31-08-2017	11637	-	-	7:10
Firma Signature	RossiC	GuidettiM	File	Codice Grezzo / Master Code	Formato/Size
			02004636	-	A4



CASAPPA®
FLUID POWER DESIGN

The information hereon is the property of CASAPPA Spa. Without written permission, any copying, trasmittal to others and any use except that for which it's loaned, is prohibited.

Descrizione / Description

POMPA PLP20.4D0-82E2-LEA/EA-N-EL FS
PUMP PLP20.4D0-82E2-LEA/EA-N-EL FS

Codice / Code

02004636

Sostituisce / It replaces

-

Ind. Mod./ Index Rev.

2